

MOTOR SPECS/PERFORMANCE DATA	
MODEL NUMBER	YXNS644
HP	.75
VOLT	208-230/460
PHASE	3
HZ	60
RATED SPEED	1740 RPM
FLA (@460VOLT)	1.2 AMPS
FRAME	56C
ENCLOSURE	TEV
INSULATION	F
INS CLASS	55
EFFICIENCY	82%
POWER FACTOR	76%
FULL LOAD TORQUE	3 Nm (2.21 ft-lbs)
VAV TORQUE	10.5 Nm (7.75 ft-lbs)
START AMPERAGE	10 AMPS
SERVICE FACTOR	1.15
RATING	40 C AMBIENT
LOCKED MOTOR CODE	2.4
TECHN DESIGN CODE	B
TR KVA CODE	0.65 AMPS
NO LOAD CURRENT	1.6 OHMS
LINE LINE RESIST @50	2.2 C
TEMP RISE COEFF	9 Nm (6.64 ft-lbs)
LOCKED ROTOR TORQ	85 C
TEMP RISE @ST LOAD	38
SHIPPING WEIGHT (LBS)	CONTINUOUS
DUTY	

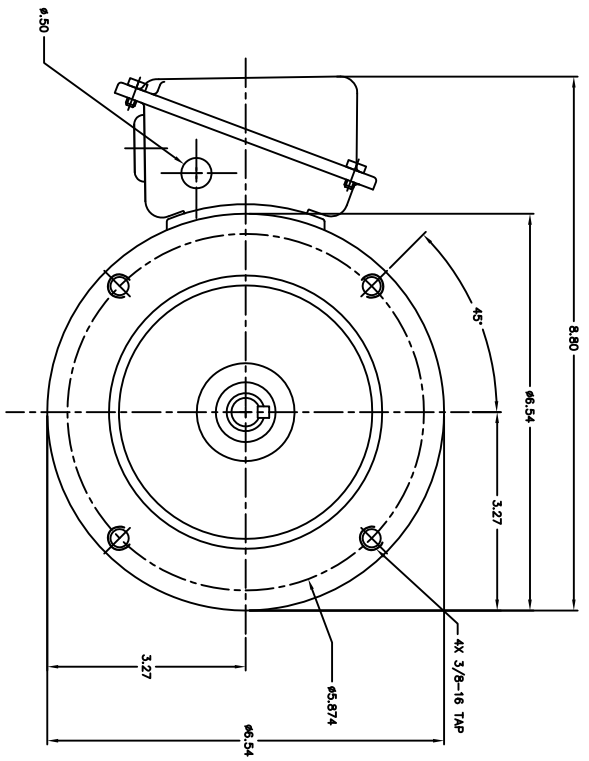

MOTOR SPECS/PERFORMANCE DATA	
MODEL NUMBER	YXNS644
HP	.75
VOLT	208-230/460
PHASE	3
HZ	60
RATED SPEED	1740 RPM
FLA (@460VOLT)	1.2 AMPS
FRAME	56C
ENCLOSURE	TEV
INSULATION	F
INS CLASS	55
EFFICIENCY	82%
POWER FACTOR	76%
FULL LOAD TORQUE	3 Nm (2.21 ft-lbs)
VAV TORQUE	10.5 Nm (7.75 ft-lbs)
START AMPERAGE	10 AMPS
SERVICE FACTOR	1.15
RATING	40 C AMBIENT
LOCKED MOTOR CODE	2.4
TECHN DESIGN CODE	B
TR KVA CODE	0.65 AMPS
NO LOAD CURRENT	1.6 OHMS
LINE LINE RESIST @50	2.2 C
TEMP RISE COEFF	9 Nm (6.64 ft-lbs)
LOCKED ROTOR TORQ	85 C
TEMP RISE @ST LOAD	38
SHIPPING WEIGHT (LBS)	CONTINUOUS
DUTY	

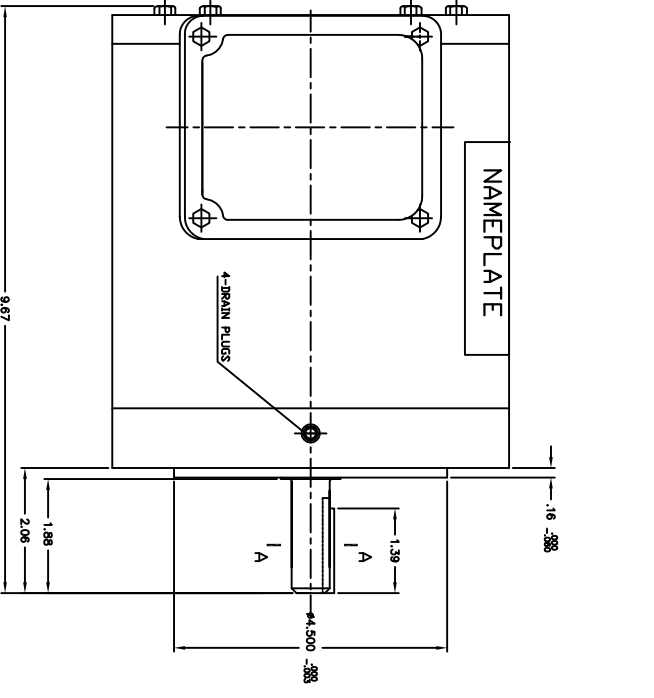
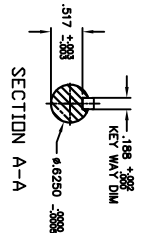
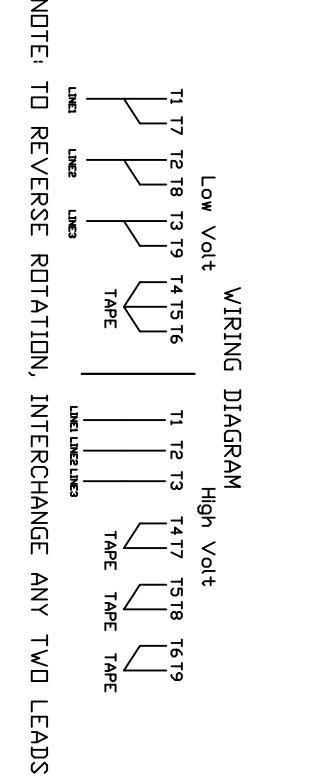

REVISIONS	
REV	DESCRIPTION
1	RELEASE FOR MESSITE
2	
3	
4	
5	
6	
7	
8	

APPLICABLE SPECIFICATIONS	APPROVALS	DATE	BY
MATERIAL N/A	DESIGNED BY		
INSPECTOR/ACCEPTANCE CRITERIA	CHECKED BY		
N/A	APPROVED BY		
	DATE		
	SCALE		
	PROJECT NO.		
	DRAWING NO.		
	REV		
	DATE		
	BY		
	CHKD		
	APP'D		
	DATE		
	SCALE		
	PROJECT NO.		
	DRAWING NO.		
	REV		
	DATE		
	BY		
	CHKD		
	APP'D		
	DATE		
	SCALE		
	PROJECT NO.		
	DRAWING NO.		
	REV		
	DATE		
	BY		
	CHKD		
	APP'D		
	DATE		
	SCALE		
	PROJECT NO.		
	DRAWING NO.		
	REV		
	DATE		
	BY		
	CHKD		
	APP'D		
	DATE		
	SCALE		
	PROJECT NO.		
	DRAWING NO.		
	REV		
	DATE		
	BY		
	CHKD		
	APP'D		
	DATE		
	SCALE		
	PROJECT NO.		
	DRAWING NO.		
	REV		
	DATE		
	BY		
	CHKD		
	APP'D		
	DATE		
	SCALE		
	PROJECT NO.		
	DRAWING NO.		
	REV		
	DATE		
	BY		
	CHKD		
	APP'D		
	DATE		
	SCALE		
	PROJECT NO.		
	DRAWING NO.		
	REV		
	DATE		
	BY		
	CHKD		
	APP'D		
	DATE		
	SCALE		
	PROJECT NO.		
	DRAWING NO.		
	REV		
	DATE		
	BY		
	CHKD		
	APP'D		
	DATE		
	SCALE		
	PROJECT NO.		
	DRAWING NO.		
	REV		
	DATE		
	BY		
	CHKD		
	APP'D		
	DATE		
	SCALE		
	PROJECT NO.		
	DRAWING NO.		
	REV		
	DATE		
	BY		
	CHKD		
	APP'D		
	DATE		
	SCALE		
	PROJECT NO.		
	DRAWING NO.		
	REV		
	DATE		
	BY		
	CHKD		
	APP'D		
	DATE		
	SCALE		
	PROJECT NO.		
	DRAWING NO.		
	REV		
	DATE		
	BY		
	CHKD		
	APP'D		
	DATE		
	SCALE		
	PROJECT NO.		
	DRAWING NO.		
	REV		
	DATE		
	BY		
	CHKD		
	APP'D		
	DATE		
	SCALE		
	PROJECT NO.		
	DRAWING NO.		
	REV		
	DATE		
	BY		
	CHKD		
	APP'D		
	DATE		
	SCALE		
	PROJECT NO.		
	DRAWING NO.		
	REV		
	DATE		
	BY		
	CHKD		
	APP'D		
	DATE		
	SCALE		
	PROJECT NO.		
	DRAWING NO.		
	REV		
	DATE		
	BY		
	CHKD		
	APP'D		
	DATE		
	SCALE		
	PROJECT NO.		
	DRAWING NO.		
	REV		
	DATE		
	BY		
	CHKD		
	APP'D		
	DATE		
	SCALE		
	PROJECT NO.		
	DRAWING NO.		
	REV		
	DATE		
	BY		
	CHKD		
	APP'D		
	DATE		
	SCALE		
	PROJECT NO.		
	DRAWING NO.		
	REV		
	DATE		
	BY		
	CHKD		
	APP'D		
	DATE		
	SCALE		
	PROJECT NO.		
	DRAWING NO.		
	REV		
	DATE		
	BY		
	CHKD		
	APP'D		
	DATE		
	SCALE		
	PROJECT NO.		
	DRAWING NO.		
	REV		
	DATE		
	BY		
	CHKD		
	APP'D		
	DATE		
	SCALE		
	PROJECT NO.		
	DRAWING NO.		
	REV		
	DATE		
	BY		
	CHKD		
	APP'D		
	DATE		
	SCALE		
	PROJECT NO.		
	DRAWING NO.		
	REV		
	DATE		
	BY		
	CHKD		
	APP'D		
	DATE		
	SCALE		
	PROJECT NO.		
	DRAWING NO.		
	REV		
	DATE		
	BY		
	CHKD		
	APP'D		
	DATE		
	SCALE		
	PROJECT NO.		
	DRAWING NO.		
	REV		
	DATE		
	BY		
	CHKD		
	APP'D		
	DATE		
	SCALE		
	PROJECT NO.		
	DRAWING NO.		
	REV		
	DATE		
	BY		
	CHKD		
	APP'D		
	DATE		
	SCALE		
	PROJECT NO.		
	DRAWING NO.		
	REV		
	DATE		
	BY		
	CHKD		
	APP'D		
	DATE		
	SCALE		
	PROJECT NO.		
	DRAWING NO.		
	REV		
	DATE		
	BY		
	CHKD		
	APP'D		
	DATE		
	SCALE		
	PROJECT NO.		
	DRAWING NO.		
	REV		
	DATE		
	BY		
	CHKD		
	APP'D		
	DATE		
	SCALE		
	PROJECT NO.		
	DRAWING NO.		
	REV		
	DATE		
	BY		
	CHKD		
	APP'D		
	DATE		
	SCALE		
	PROJECT NO.		
	DRAWING NO.		
	REV		
	DATE		
	BY		
	CHKD		
	APP'D		
	DATE		
	SCALE		
	PROJECT NO.		
	DRAWING NO.		
	REV		
	DATE		
	BY		
	CHKD		
	APP'D		
	DATE		
	SCALE		
	PROJECT NO.		
	DRAWING NO.		
	REV		
	DATE		
	BY		
	CHKD		
	APP'D		
	DATE		
	SCALE		
	PROJECT NO.		
	DRAWING NO.		
	REV		
	DATE		
	BY		
	CHKD		
	APP'D		
	DATE		
	SCALE		
	PROJECT NO.		
	DRAWING NO.		
	REV		
	DATE		
	BY		
	CHKD		
	APP'D		
	DATE		
	SCALE		
	PROJECT NO.		
	DRAWING NO.		
	REV		
	DATE		
	BY		
	CHKD		